



取扱説明書

刈払機

BCS250H

注意

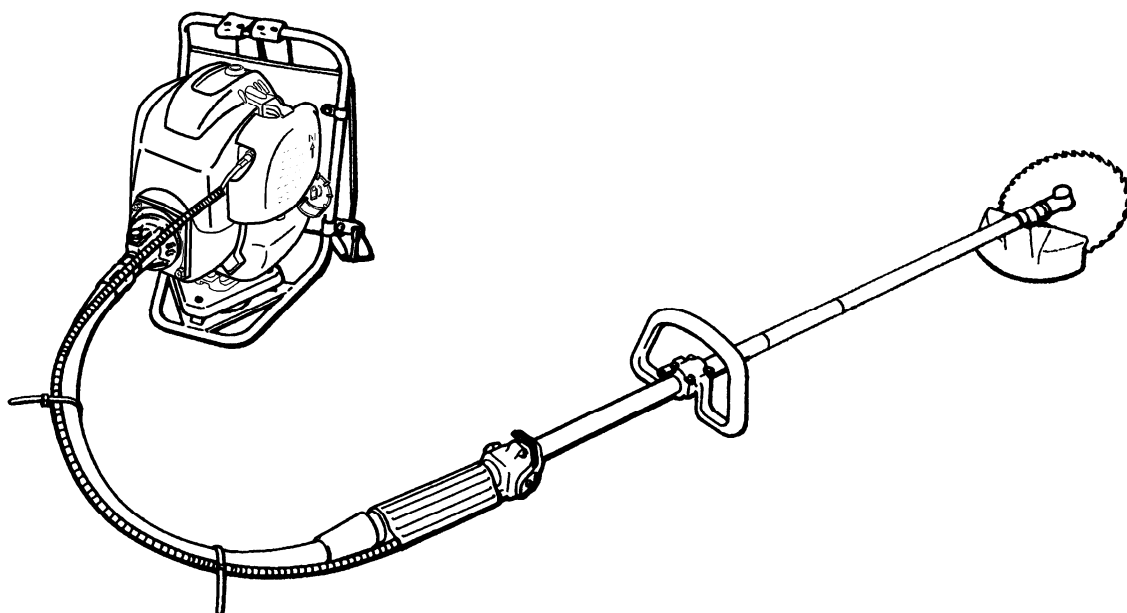

1 ⚠

2

⚠

⚠

⚠

-  危険...
-  警告...
-  注意...
- 注意...



	[min]()	1[min]=1[rpm]	[rpm]	

1 ▲ 安全に作業するために

[Empty rounded rectangular box]

▲危険 ▲警告 ▲注意 注意

[Empty rounded rectangular box]

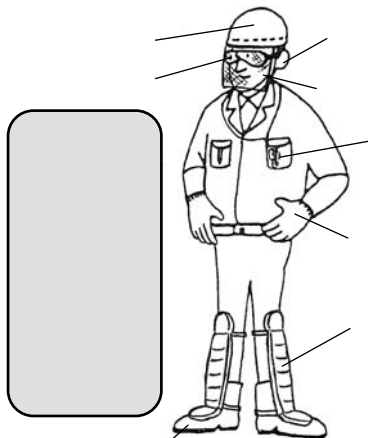

安全靴 / 耐切創長靴

[Empty rounded rectangular box]

()

P 4
P10

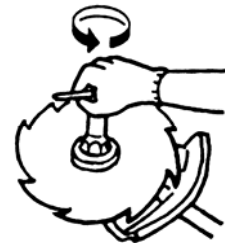

()



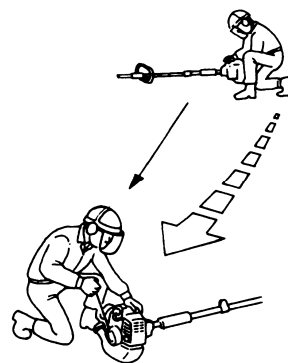
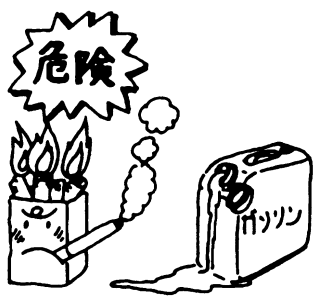

()



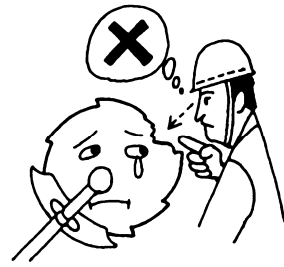

() ()

()

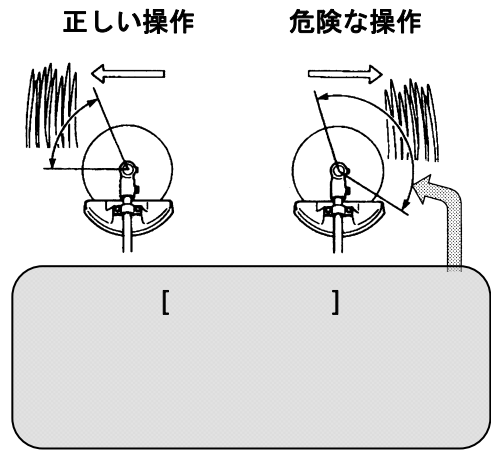

()

機械をむやみに振り回す、刈刃を膝より高くあげる

3 40

10 20

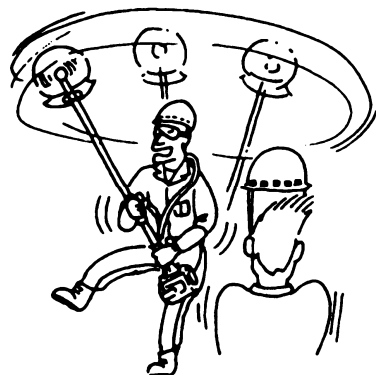

木や石にぶつける



1.

2.

3.

()

()

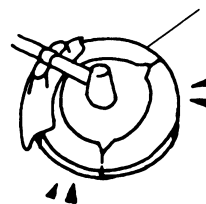

2 各部のなまえと付属品

1

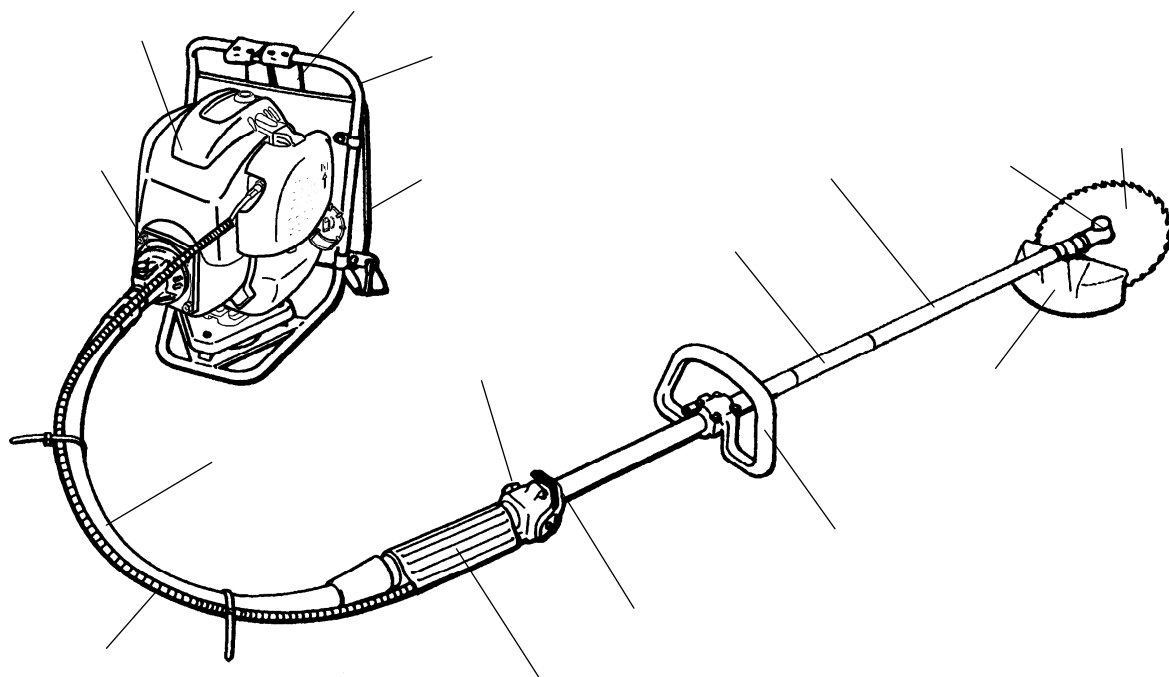

2

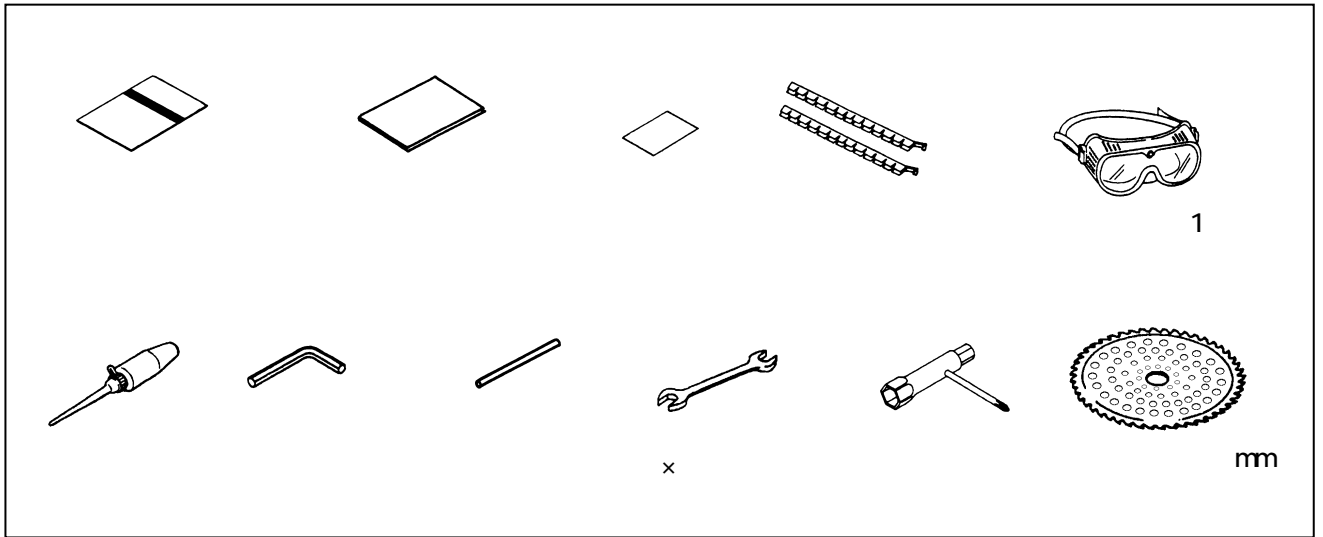

3

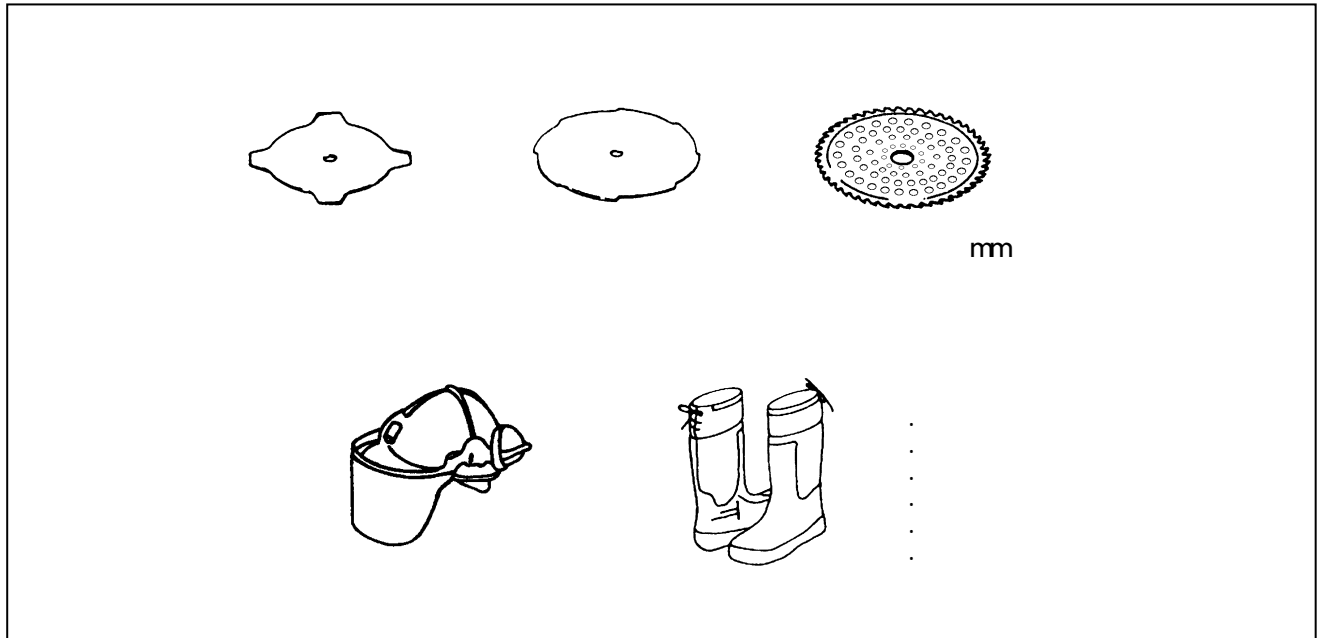

3 ▲警告ラベルの取扱い

▲注意

<p>▲ 注意</p> <ul style="list-style-type: none"> 取扱説明書を読むこと。 飛散防護カバーを取り付けること。 15m以内に、人が近づかないようにすること。 保護メガネ、耳栓、ヘルメットを着用すること。 エンジン始動は、刈刃を接地させないで行うこと。 		
---	--	--

4 主要諸元

		BCS250H	
	mm	2500	
	mm	280	
	mm	375	
	k g	7.9	
		1 : 1.33	
		255mm	
		GX25	
		4	(OHC)
		25	
(4)	API	U (SAE10W-30) SE, SF, SG SAE10W-30

5 組立

< >

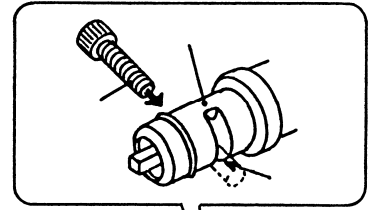

< >

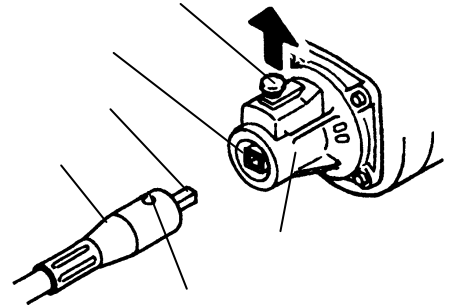
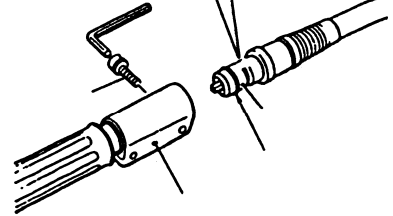

< >

()

P7

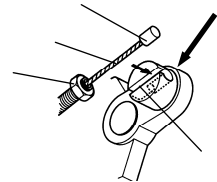

()

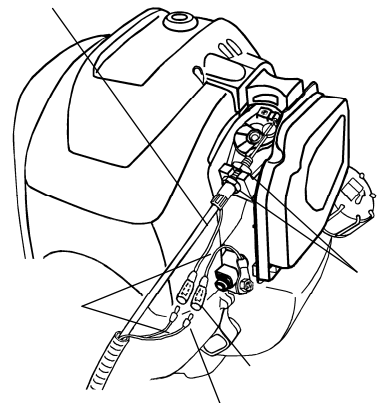

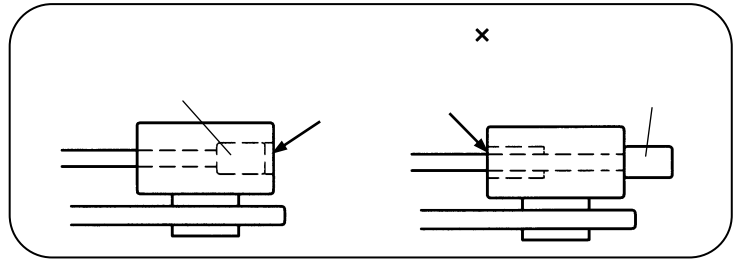
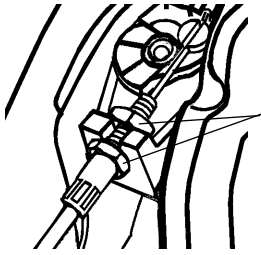
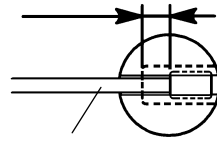
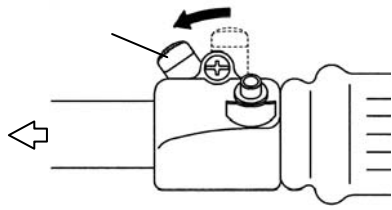

< >

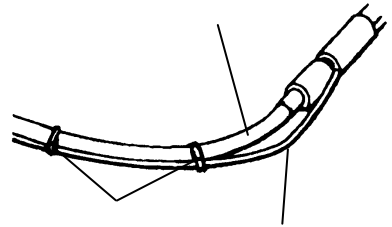

< >

()

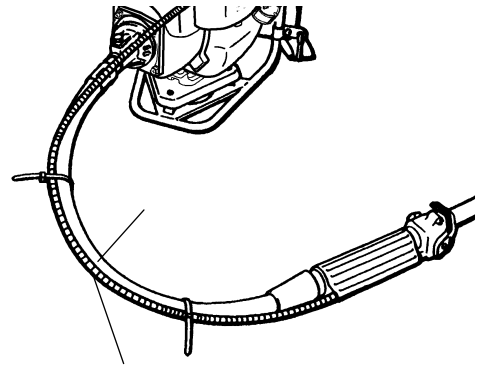

3

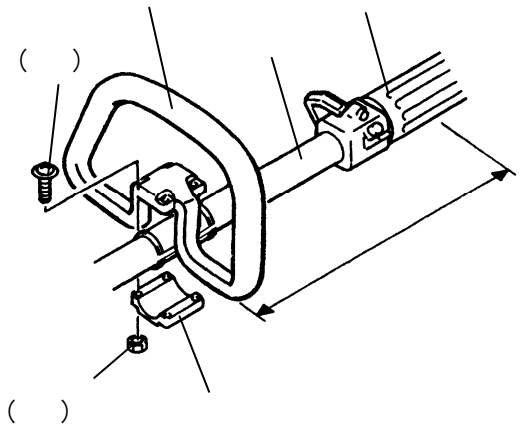

4

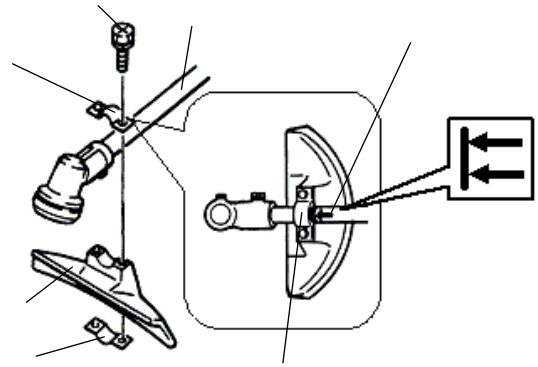

5



()

()



42cm

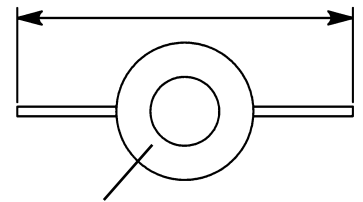

6

注意

[Redacted]

注意

[Redacted] ()

3.5 170

()

()

()

3.5 170

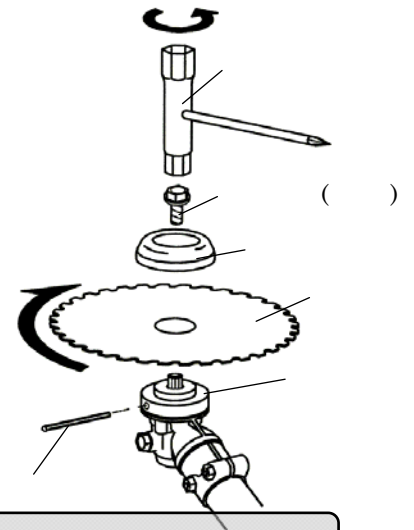

[Redacted]

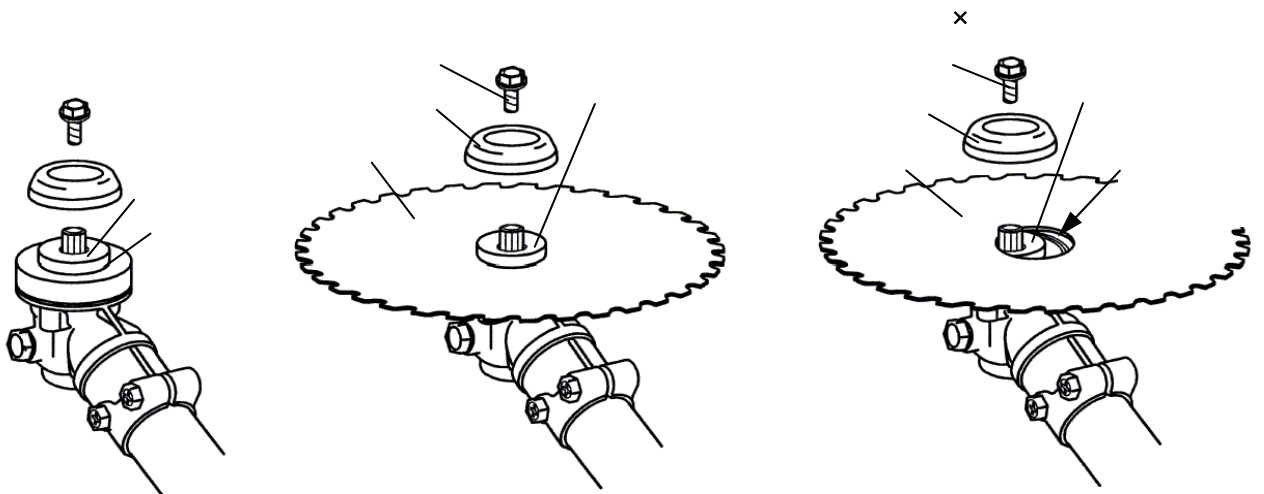

警告

[Redacted]

警告

[Redacted] 6

注意

[Redacted]

3.5 170

()

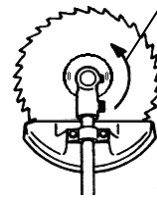
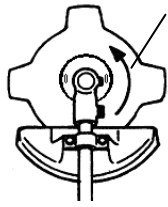

7

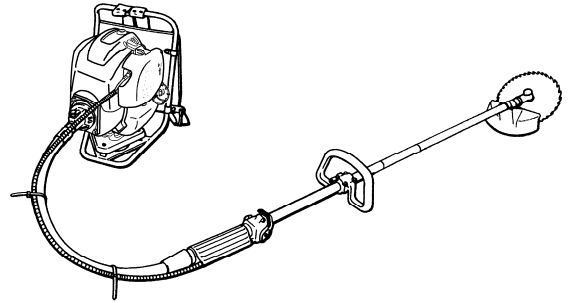

! 注意

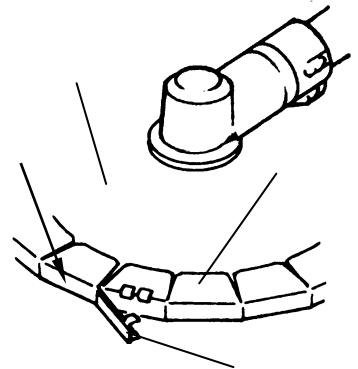

6 作業の準備

! 注意



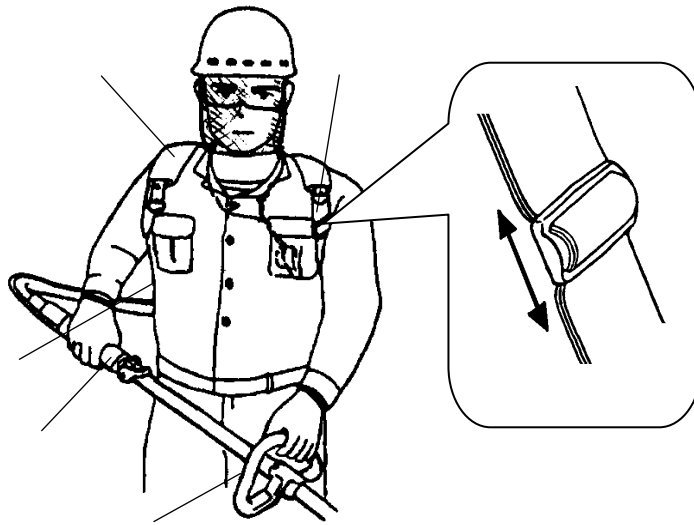

		[P.7(1)
]

•
•
•
•

()

7 刈払い作業

警告

注意

9()

危険

警告

注意

警告

注意

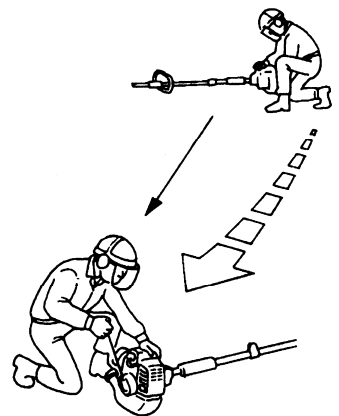

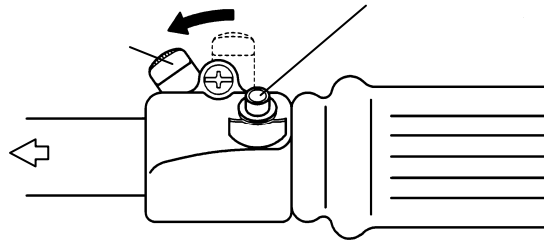

! 警告

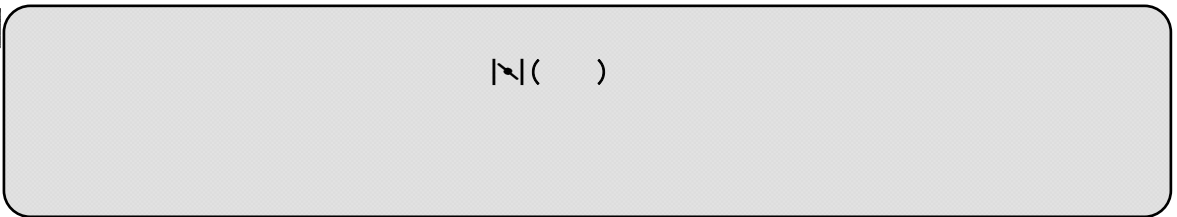

注意



! 警告



! 警告

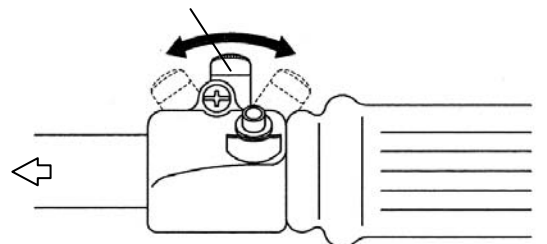

! 警告

[]

()

注意

[]

! 警告

[]

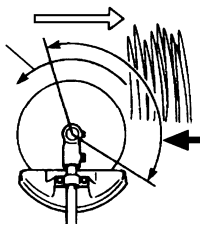
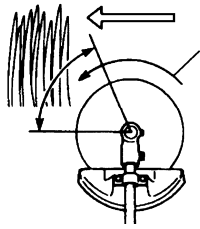

[]

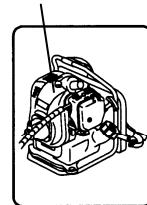
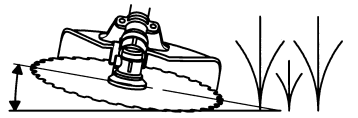
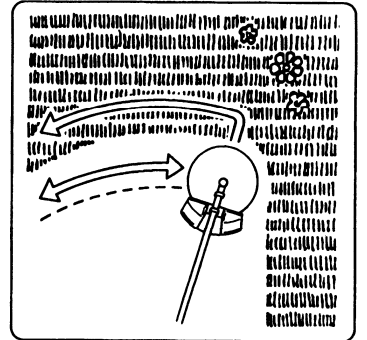

() ()

! 警告

[]

! 警告

[]

8 点検・整備

⚠ 警告

[Redacted text box]

⚠ 注意

[Redacted text box]

⚠ 注意

[Redacted text box]

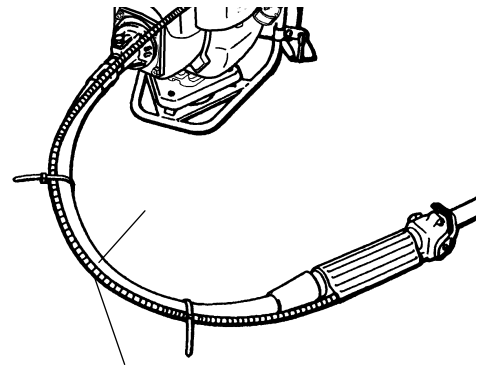

*

(P7)

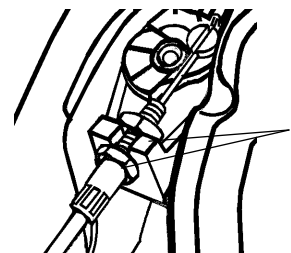
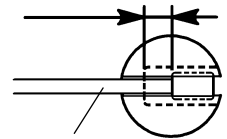

()

()

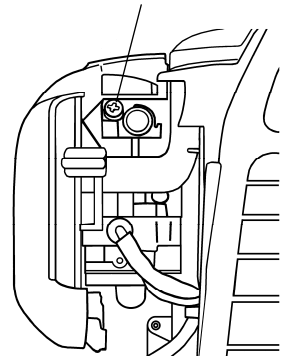

▲ 注意



]

[10 6

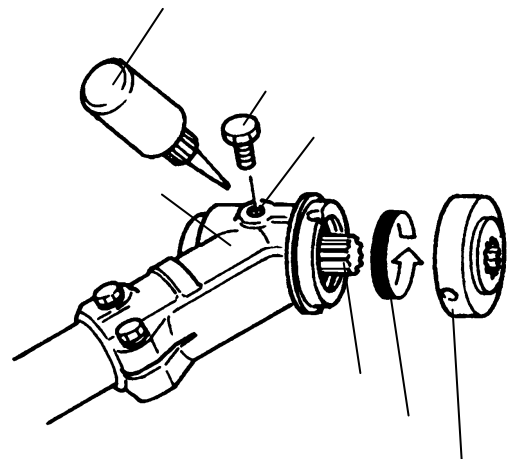
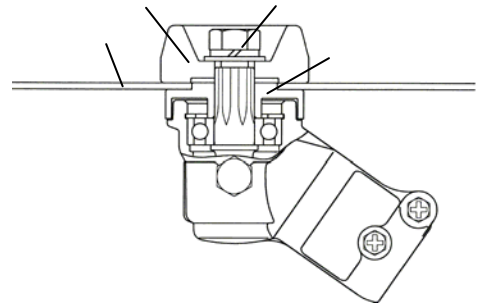

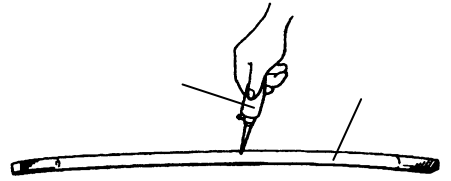
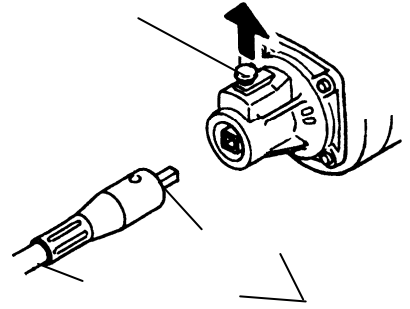

() ()
() ()

9 長期保管



10 故障と対策

	[17(2)]

	[18()]
	[P10()]

	[()]





9:00 17:00

BCS250H

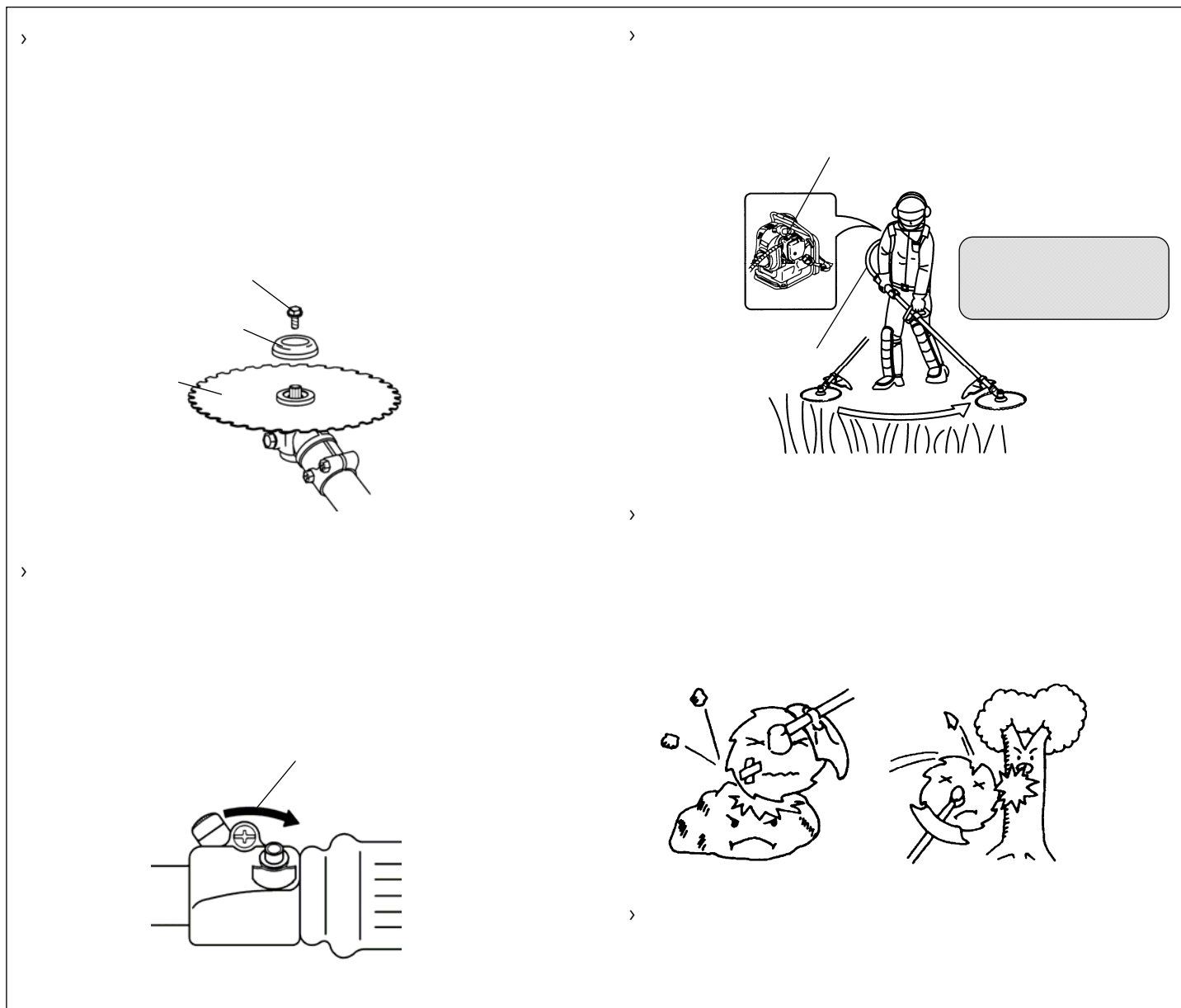

P14 6

4 主要諸元

	BCS250H
kg	8.1

1

3

10m/s^2 3
 1 10 1 2
 10m/s^2 1 10 1

$T = 200 \div a \times a$ T 1 a 3 m/s^2

3

			BCS250H
3	m/s^2	1	2.9
	kg	2	8.1

1

3

ISO 22867:2004

2